

LEL023 Order Form

Date _____
 AVFI Sales REP _____
 Customer Signature _____

Quote No. _____
 Customer No. _____
 AVFI No. _____

To generate your order form, please refer to the information provided below to insert the alphabetic and/or numeric code in the respective category boxes. Please note that without this filled out Order Form, your purchase **cannot** be processed.

1	2	3	4
Product Model	Finish	Chargeable Accessories	Custom Cutouts
LEL023			

1 Product Model



Code **LEL023**

3 Choose Product Finish

Standard Finishes (Ships within 1-14 days)



Optional Finishes (Ships within 28 days)



2 Chargeable Accessories (Check all that apply)

- Code **0** No Accessories
- Code **K3** PLM1022 LCD Monitor Mount.....Qty _____
- * Code **D1** MIC-18 MX418C Microphone.....Qty _____
- * Code **D2** LIGHT-18 Littlite Gooseneck.....Qty _____
- * Code **D3** FM3 Countdown Timer/ Clock.....Qty _____
- Code **E1** PB 6 Outlet Power Bar.....Qty _____
- Code **E3** CUB3 Round Cable Well.....Qty _____
- * Code **EB** CUB4B Black Power Panel.....Qty _____
- * Code **E7** PC-PATCH Power-Data Module.....Qty _____
- * Code **EJ** CUB22 Black 3 Module Panel.....Qty _____
- * Code **EK** CUBM3 3 Module Power & Data Panel.....Qty _____
- * Code **EL** CUBM4 4 Module Power & Data Panel.....Qty _____
- * Code **EF** CHGQiB Wireless Charging Station.....Qty _____
- Code **P10** 50CAS Easy Maneuvering Casters.....Qty _____
- * Code **K8** WM2342 400x400 VESA TV Display Mount.....Qty _____
- Code **K1** C900S Single Monitor Arm.....Qty _____
- Code **K2** C900D Dual Monitor Arm.....Qty _____

* Cutout Required (Extra Charges will apply)

4 Choose Combination Finish (Optional)

If you require a different colour combination from what's seen in the 'Product Model' section; please select two product finish options for areas labeled 1 and 2.

Place product finish **code** on the line below.

1 _____
 2 _____

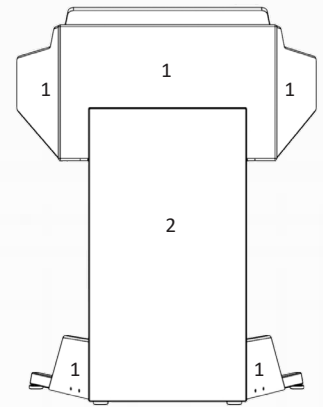

Comments (Please use this section to provide additional information)

Notes

CAD Drawings/Symbols

CAD drawings are available by request at sales@vegroup.net

Custom Cutouts

Estimated lead time is 2-4 weeks from receipt of P.O. and signed drawings.

Customizations

Modifications to design such as shape and/or size variations have to be quoted on a per case basis and are applicable for quantities of 10+ only.

Date _____
 AVFI Sales REP _____
 Customer Signature _____

Quote No. _____
 Customer No. _____
 AVFI No. _____

Office Use Only

4 Custom Cutout Option (Extra charges will apply)

Please indicate custom cutout location on the drawing(s) below

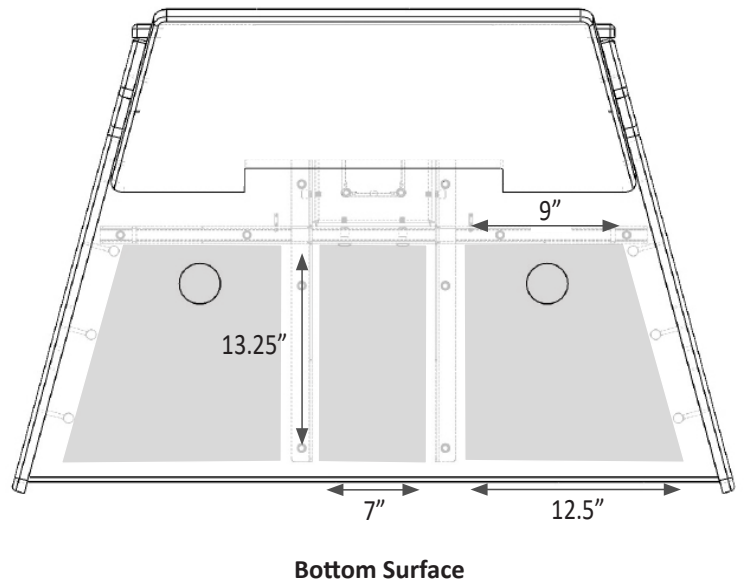
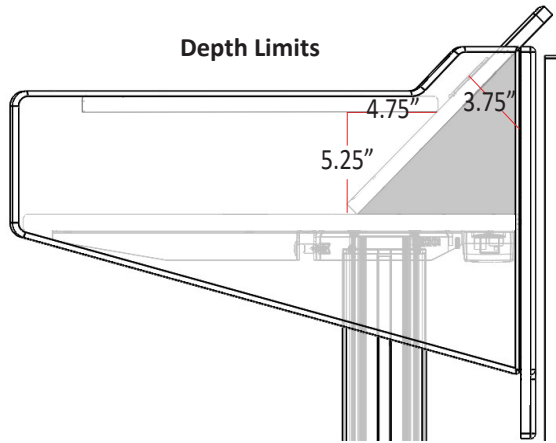
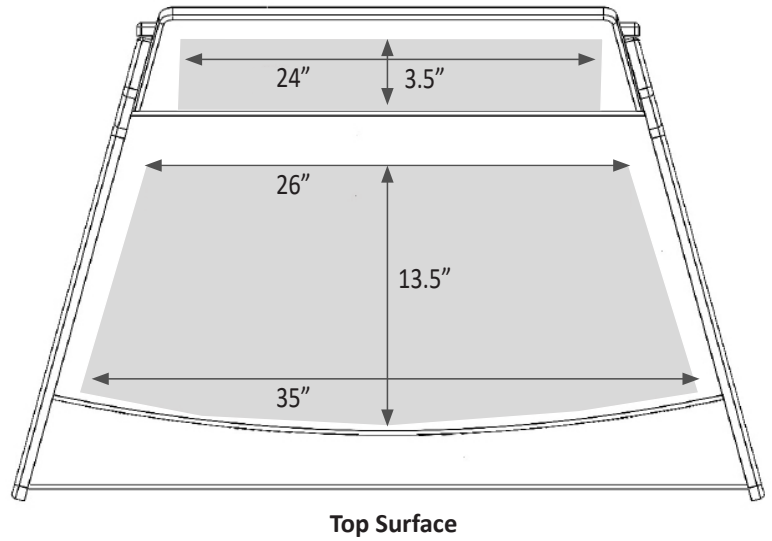
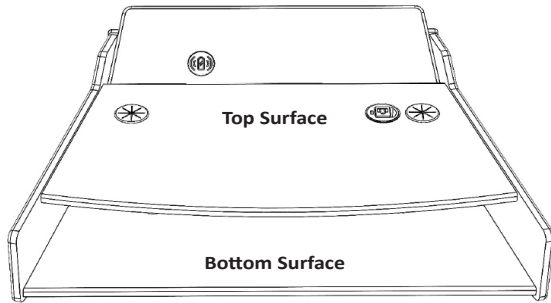

Code **CO** No Custom Cutout
 Code **CC** Custom Cutout (Specify on Cutout Area Above)
 ■ Cutout Area - Work Surface L x W